

SERPAC A27DB25

Electronic Enclosures

If machining or molding modifications are required, use the center of the enclosure to dimension

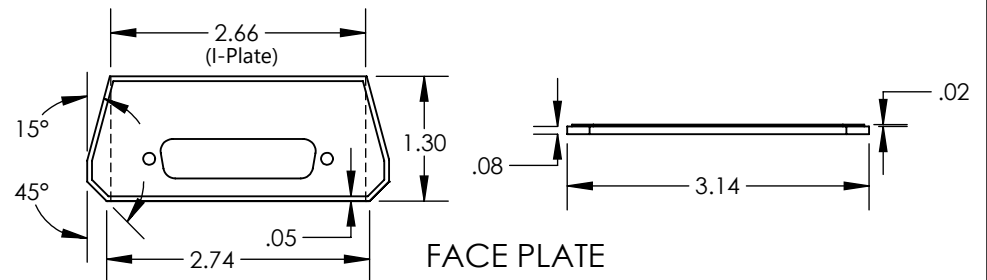
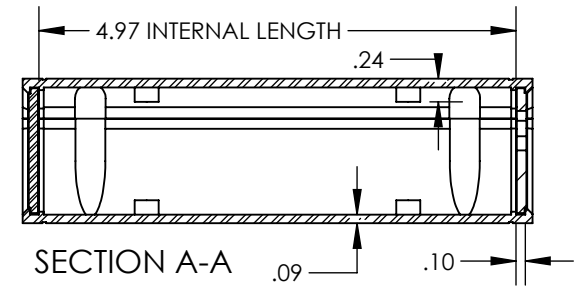
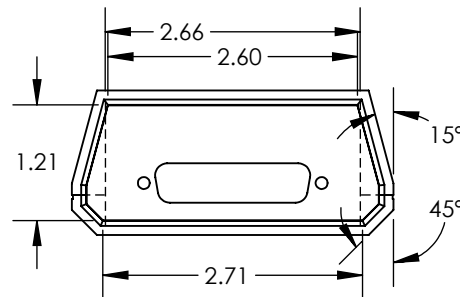
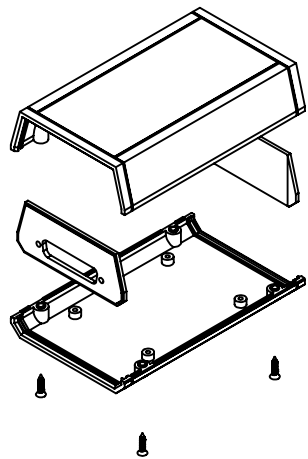
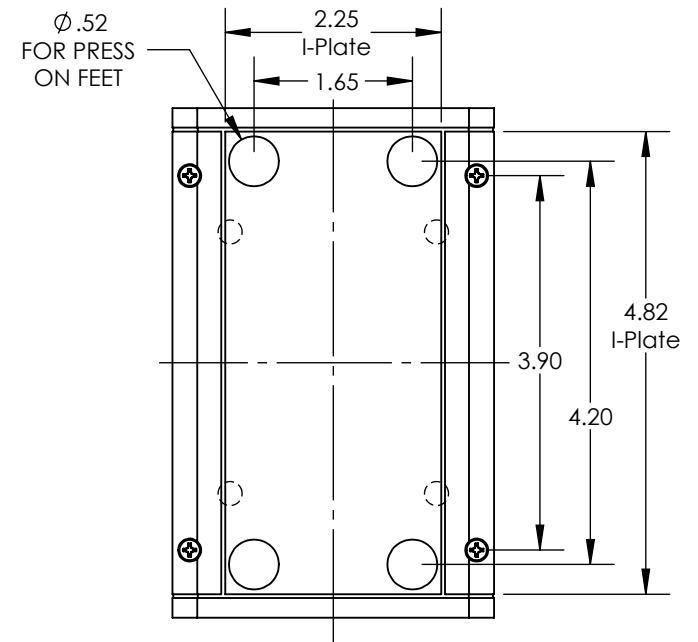
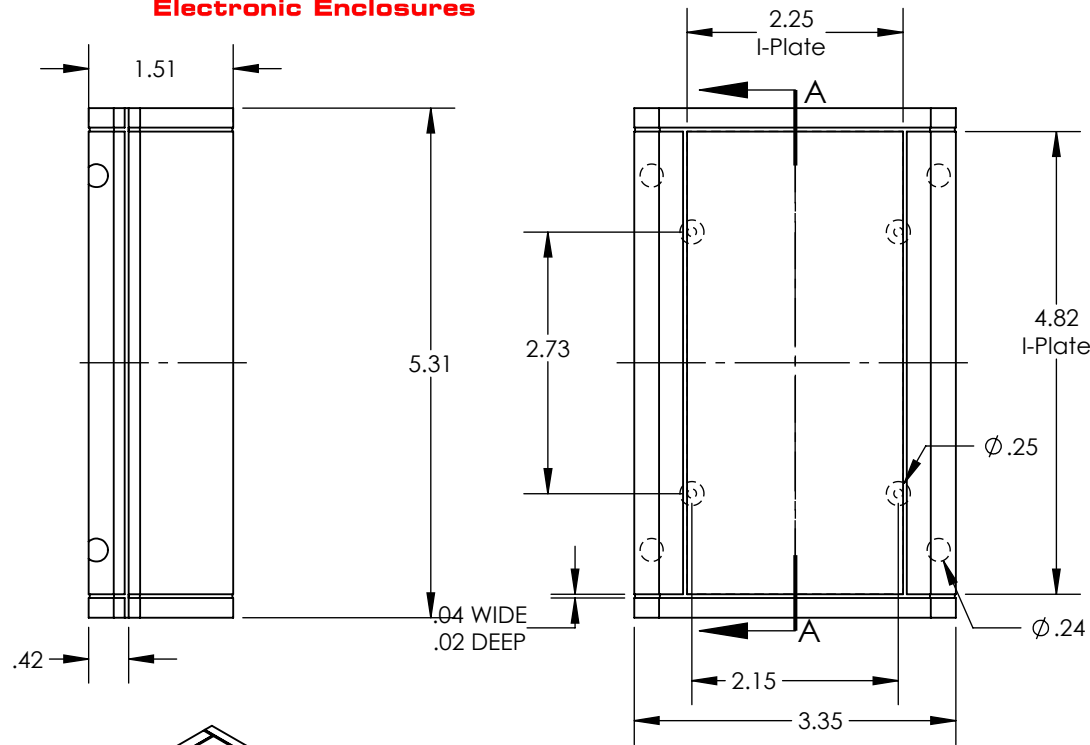

PART NO.	DESCRIPTION	ACCESSORIES	
2008	PLASTIC TOP	51	PRESS ON FEET
2010	PLASTIC END PANEL	2010CL	CLEAR & TRANSPARENT RED PANELS
2009	PLASTIC BOTTOM	2010DB9	9 PIN CONNECTOR
6006	SCREW		
2010DB25	25 PIN CONNECTOR		

ALL DIMENSIONS ARE ± .010" 5/9/2025
 2009 Wright Ave., La Verne, CA 91750
 Ph. (626) 331-0517 Fx. (626) 331-8584 serpac.com