

# SERPAC WM092R

ELECTRONIC ENCLOSURES

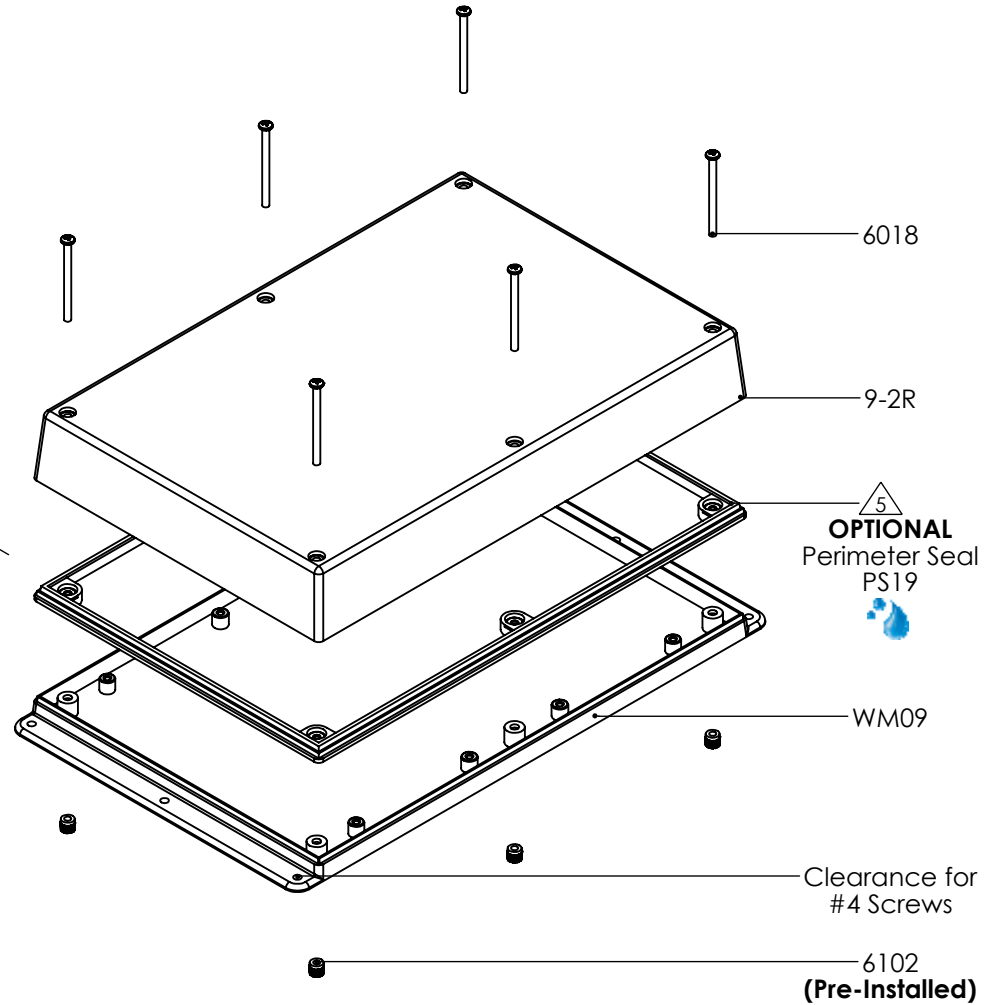
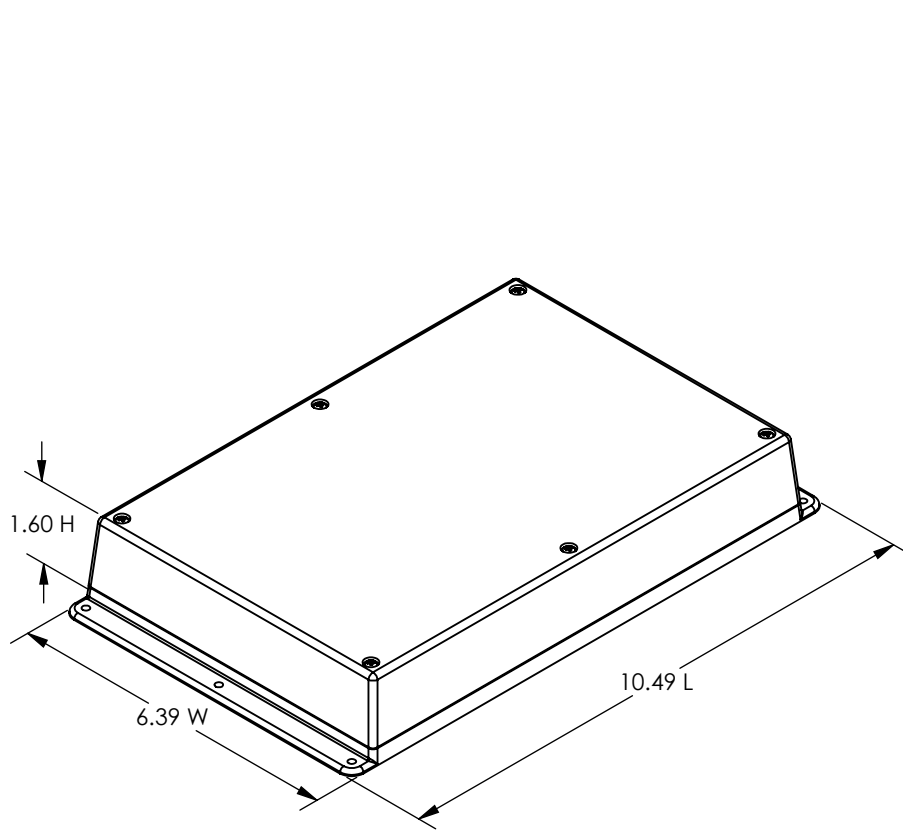

PART NO.	DESCRIPTION (Included)	ACCESSORIES (Optional)	
9-2R	Top	PART NO.	DESCRIPTION
WM09	Wall Mount Bottom	PS19	Waterproof Perimeter Seal
6018	4-40 x 1 1/2" Screw (6)	1040	2AA Battery Holder
6102	4-40 Threaded Inserts (6)	60	Standoff Hole
		61	Standoff Post

Notes: Enclosure weight .65 lb / 296 g

- 1) Enclosure meets or exceeds IP40 and NEMA 1
- 2) Circuit Board drawings see sheet 3.
- 3) All components are RoHS Compliant.
- 4) Material: Top and Bottom ABS.
- 5) When used with PS19 the enclosure meets or exceeds IP 67 and NEMA 4X, 12 and 13 MIL-STD-810G 506.5 (.04 lb / 19g)

# SERPAC WM092R

ELECTRONIC ENCLOSURES

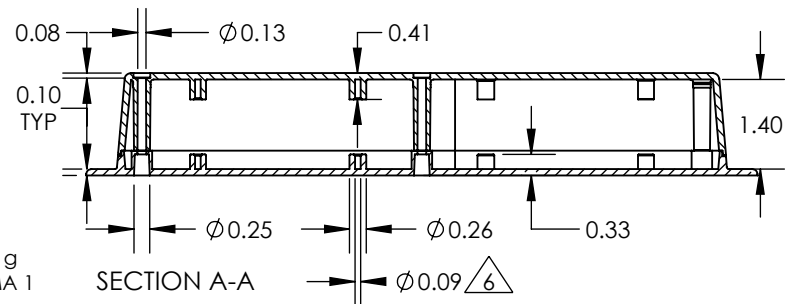
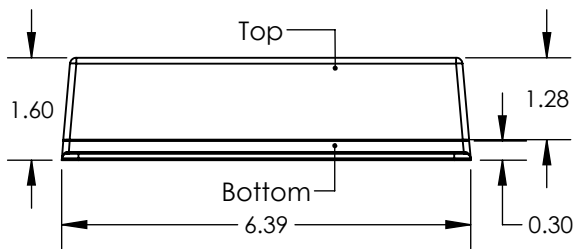
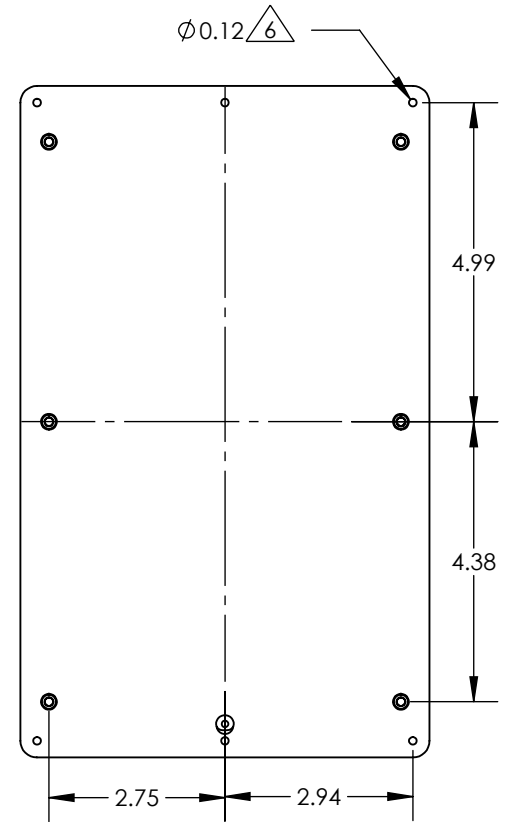
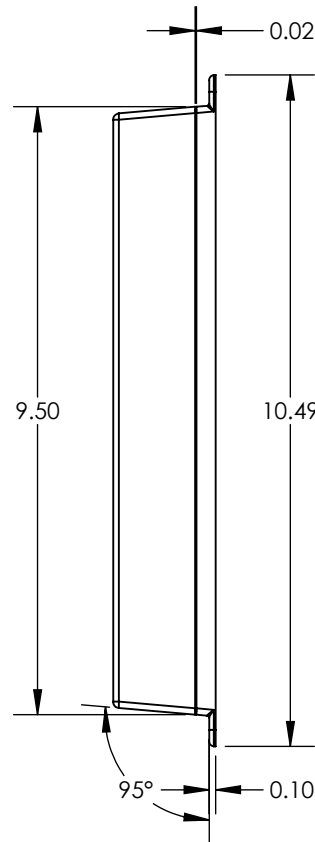
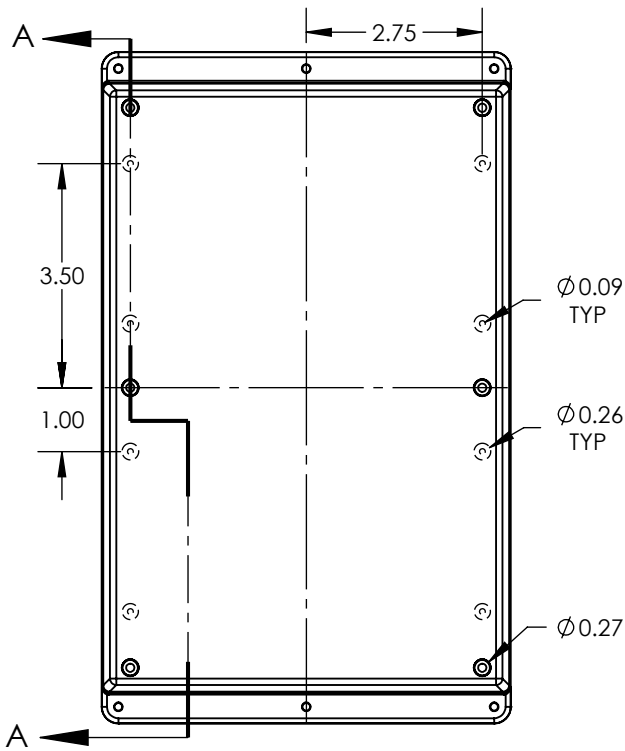

- Notes:
- 1) Enclosure weight .65 lb / 296 g
  - 2) Enclosure meets or exceeds IP40 and NEMA 1
  - 3) Circuit Board drawings see sheet 3.
  - 4) All components are RoHS Compliant.
  - 5) Material: Top and Bottom ABS.
  - 6) When used with PS19 the enclosure meets or exceeds IP 67 and NEMA 4X, 12 and 13 MIL-STD-810G 506.5 (.04 lb / 19g)
  - 7) Accepts #4 self tapping screw.  $\triangle 6$

# SERPAC WM092R CIRCUIT BOARD

ELECTRONIC ENCLOSURES

## Top & Bottom Option

