

SERPAC WM051

ELECTRONIC ENCLOSURES

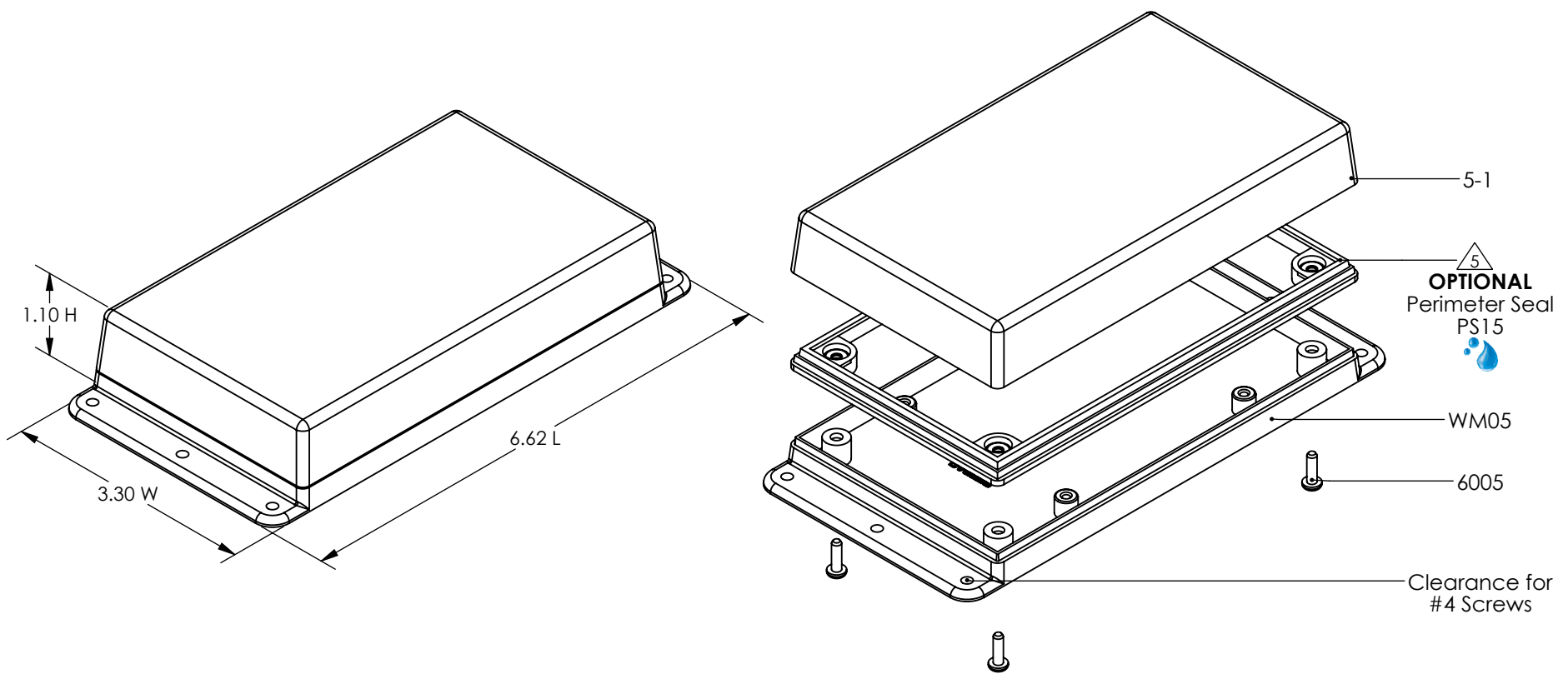

PART NO.	DESCRIPTION (Included)	ACCESSORIES (Optional)	
5-1	Top	PART NO.	DESCRIPTION
WM05	Wall Mounted Bottom	60	Standoff Hole
6005	#4X3/8" Self-Tapping Screw (4)	61	Standoff Post
		PS15	Waterproof Perimeter Seal
		1040	2AA Battery Holder

Notes: Enclosure weight .22 lb / 101 g

- 1) Enclosure meets or exceeds IP40 and NEMA 1
- 2) Circuit Board drawings see sheet 3.
- 3) All components are RoHS Compliant.
- 4) Material: Top and Bottom ABS.
- 5) When used with PS15 the enclosure meets or exceeds IP 67 and NEMA 4X, 12 and 13 MIL-STD-810G 506.5 (.02 lb / 11g)

SERPAC WM051

ELECTRONIC ENCLOSURES

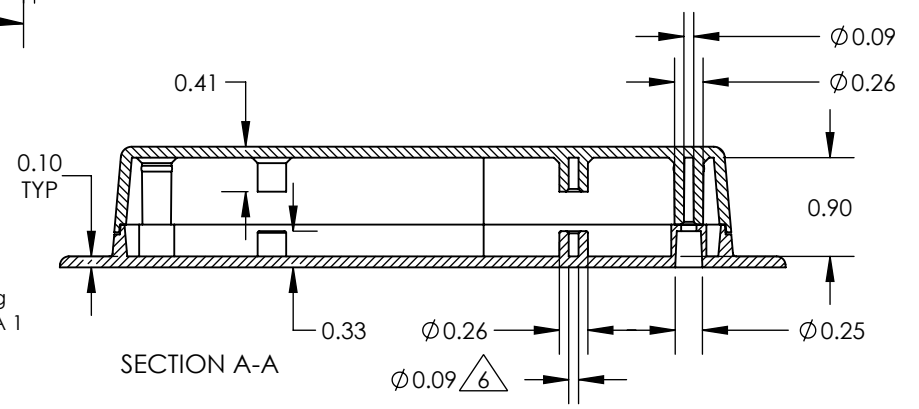
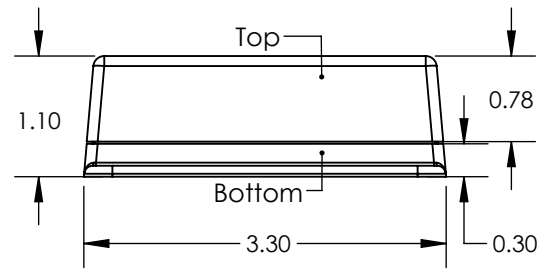
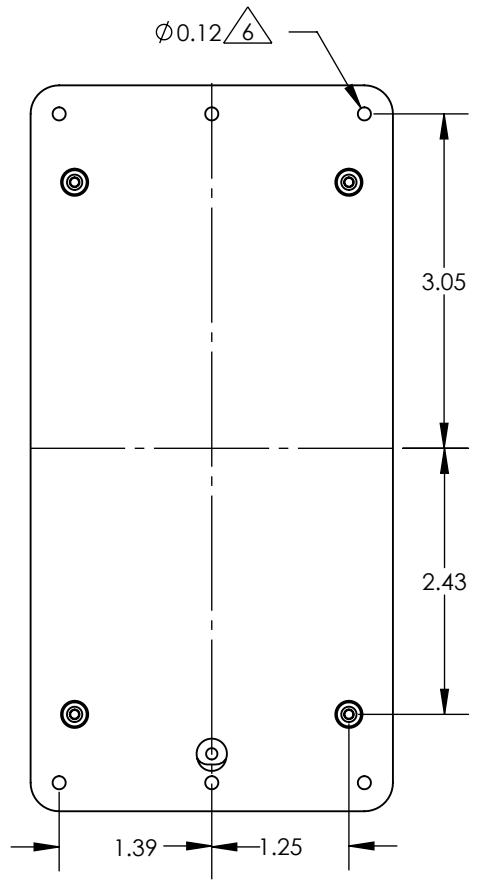
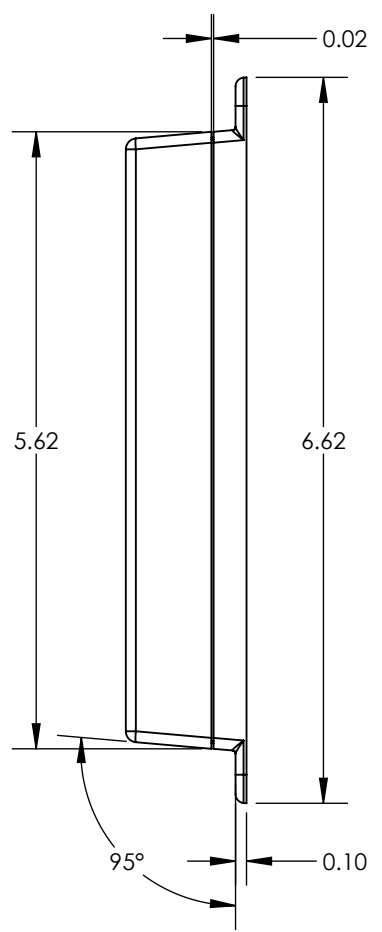
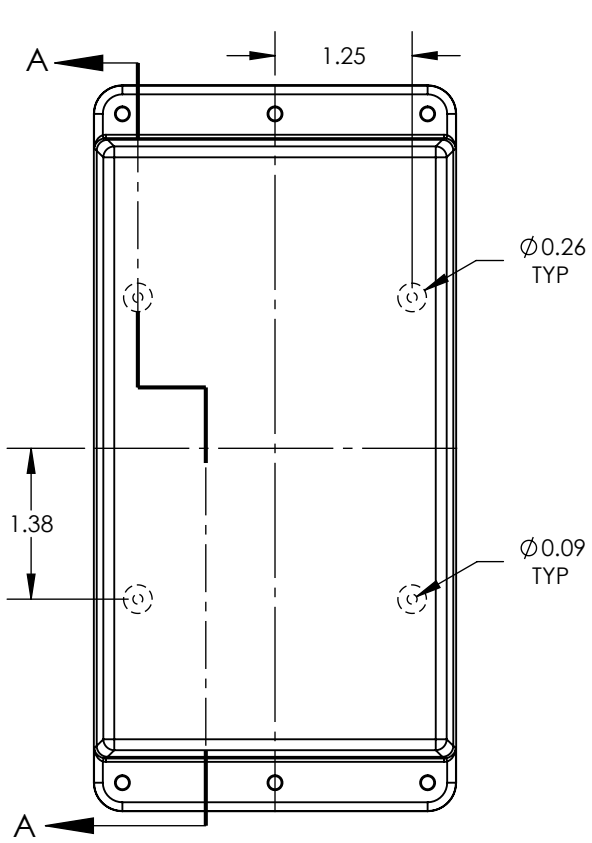

- Notes:
- Enclosure weight .22 lb / 101 g
 - 1) Enclosure meets or exceeds IP40 and NEMA 1
 - 2) Circuit Board drawings see sheet 3.
 - 3) All components are RoHS Compliant.
 - 4) Material: Top and Bottom ABS.
 - 5) When used with PS15 the enclosure meets or exceeds IP 67 and NEMA 4X, 12 and 13 MIL-STD-810G 506.5 (.02 lb / 11g)
 - 6) Accepts #4 self tapping screw.

SERPAC WM051 CIRCUIT BOARD

ELECTRONIC ENCLOSURES

Top & Bottom Option

