

SE 120

SEAHORSE PROTECTIVE EQUIPMENT CASES

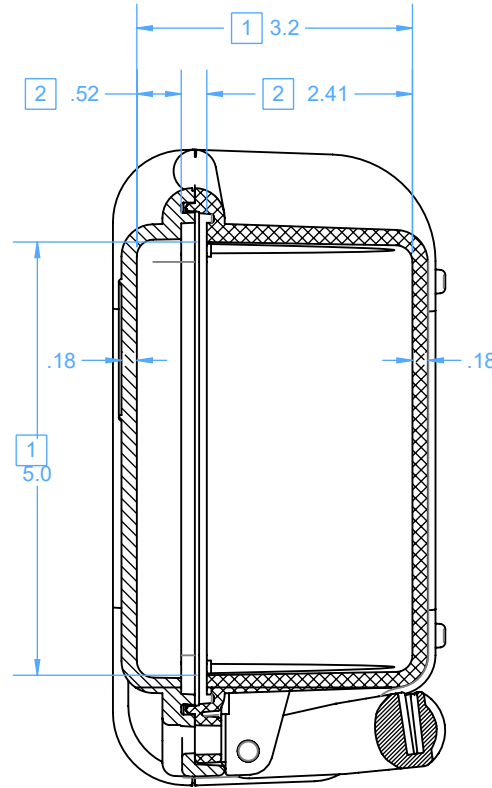

SECTION A-A

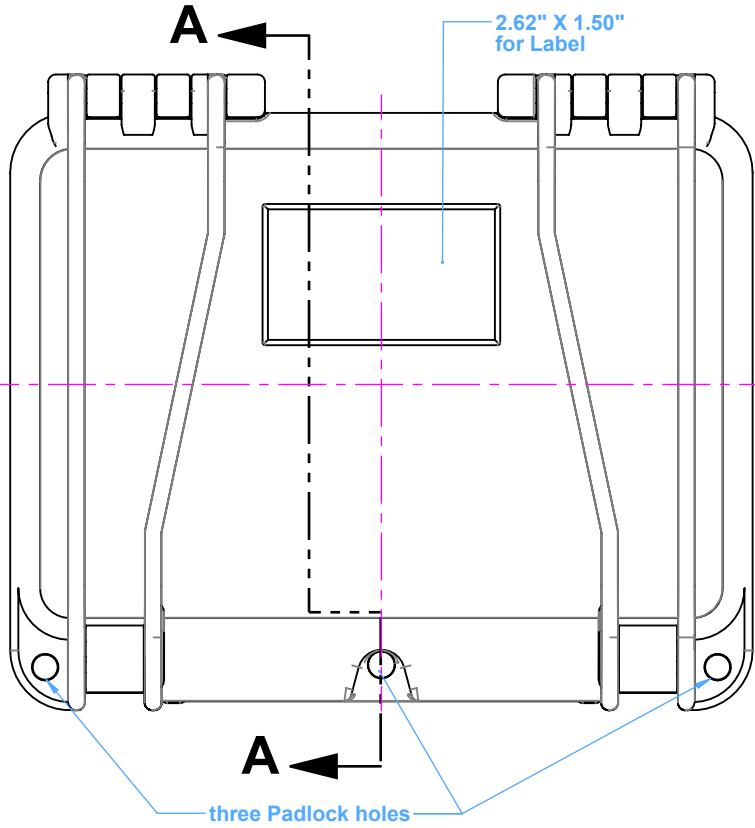
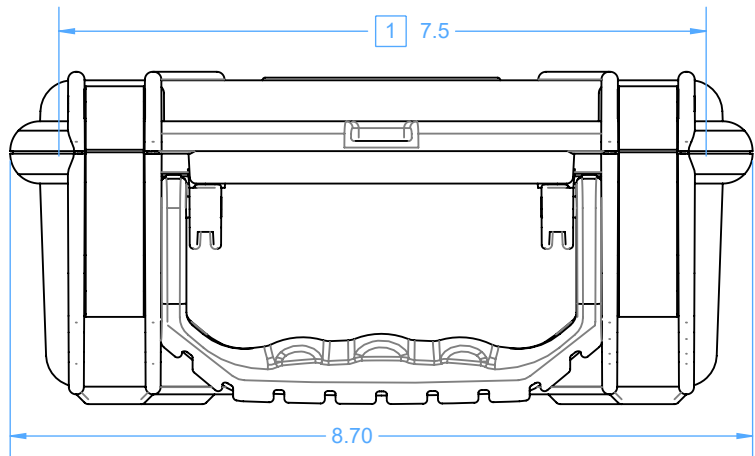
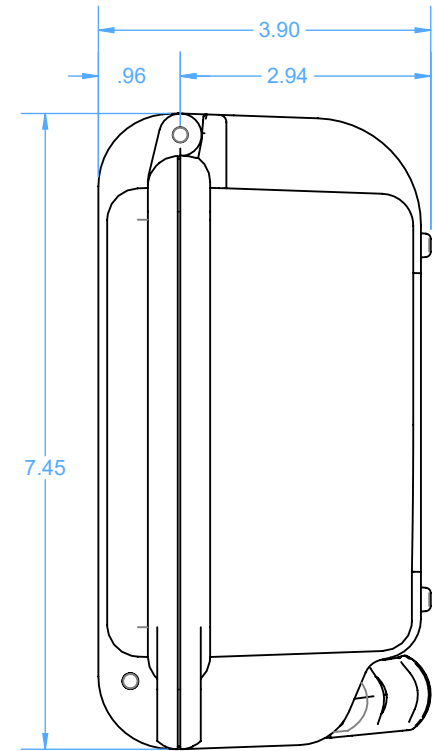

3 SE120PL
plastic lock

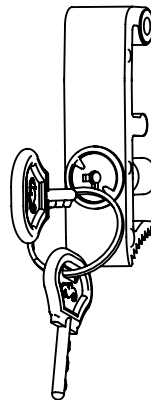

3 SE120ML
metal lock

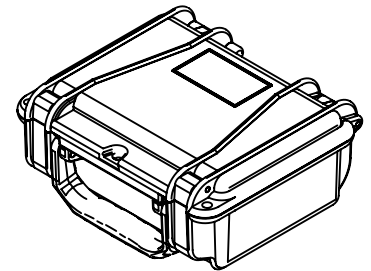
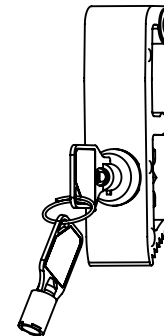

NOTES:

- 1) Max. usable inside dimensions are:
7.5" X 5" X 3.2"
- 2) Dimensions to bottom of panel flange.
- 3) Optional:
With Metal Lock Latches p/n SE120ML
With Plastic Lock Latches p/n SE120PL
- 4) Weight empty/with foam: 1.45/1.55 lb
Buoyancy: 4 lb.
Weight capacity: 20 lb.

Top panel for SE120

SEAHORSE
PROTECTIVE EQUIPMENT CASES

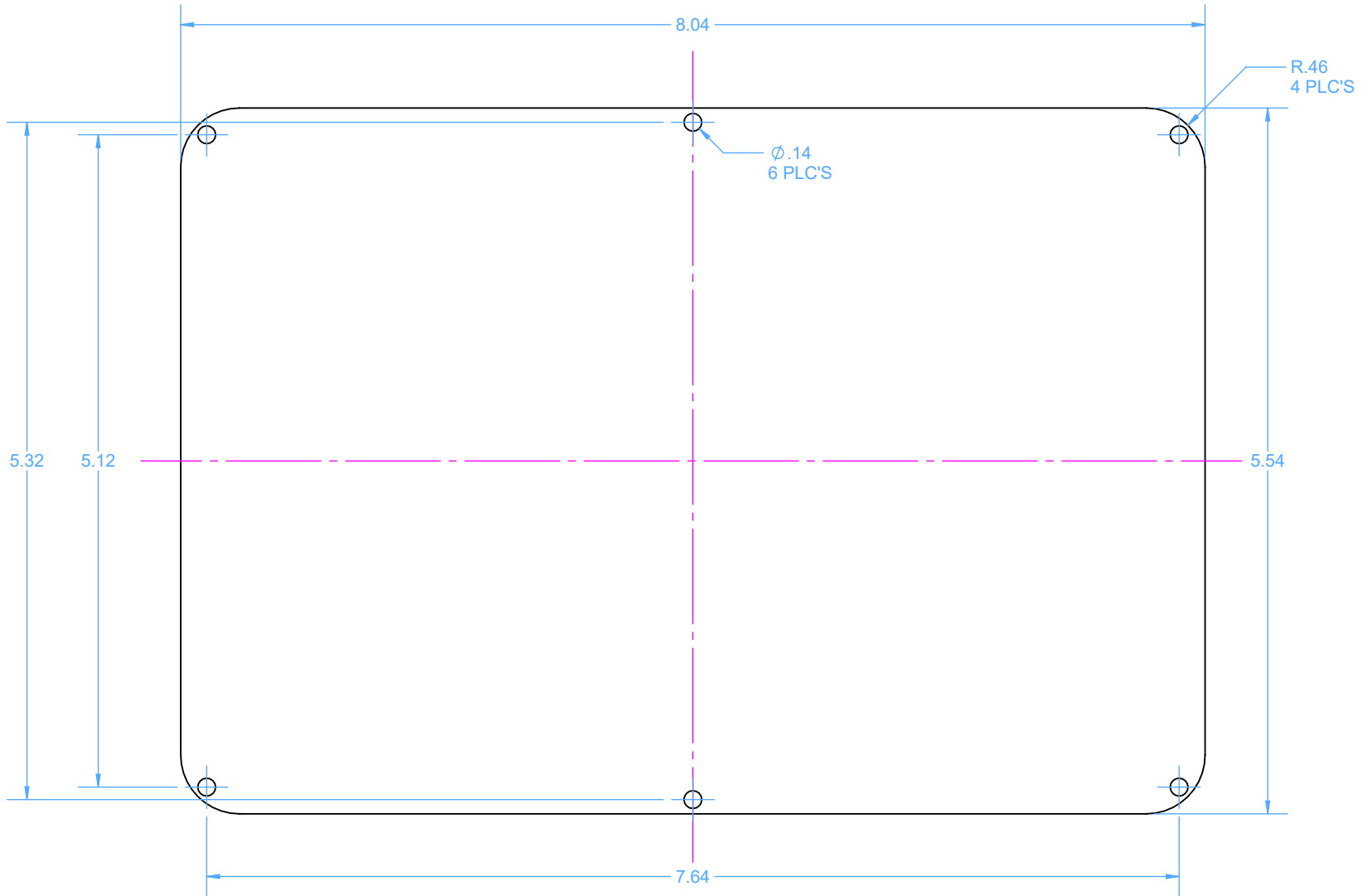

Bottom panel for SE120

SEAHORSE
PROTECTIVE EQUIPMENT CASES

