

**NOTES:**  
 1) When machine or I-plates modifications are required, use the center of the enclosure to dimension.

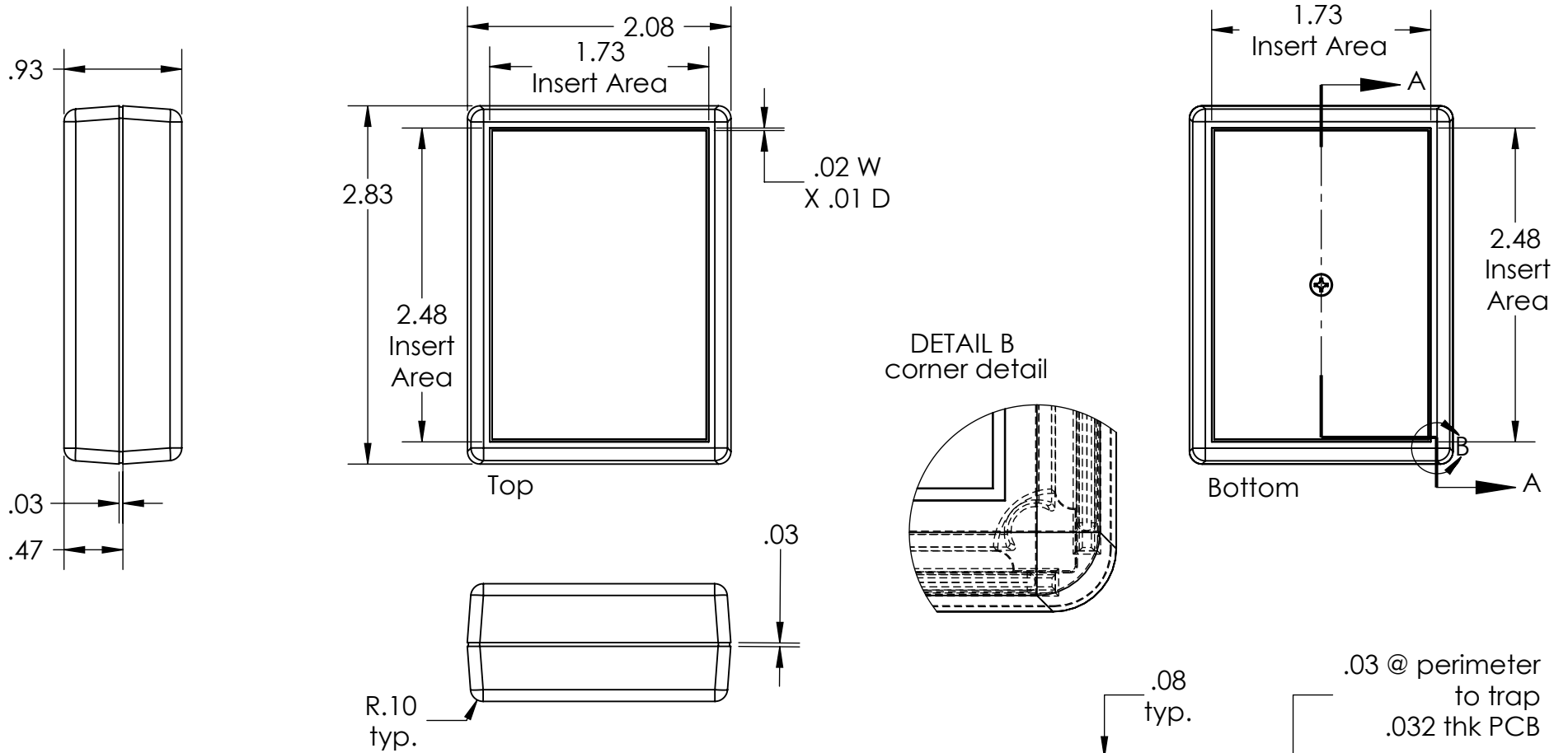

Enclosure can hold either a 0.032" PCB or a 0.063 PCB  
 PCB dimensions are: (PCB drawings on page 2)  
 Maximum PCB dimensions"  
 0.032 PCB 2.69 X 1.94  
 0.065 PCB 2.63 X 1.88

PART NO.	DESCRIPTION	ACCESSORIES	
		PART NO.	DESCRIPTION
1013	PLASTIC TOP	55	KEY HOLDER
1014	PLASTIC BOTTOM	1030	Pocket Clip
6007	SCREW(1)		

