

# SERPAC 272R

ELECTRONIC ENCLOSURES

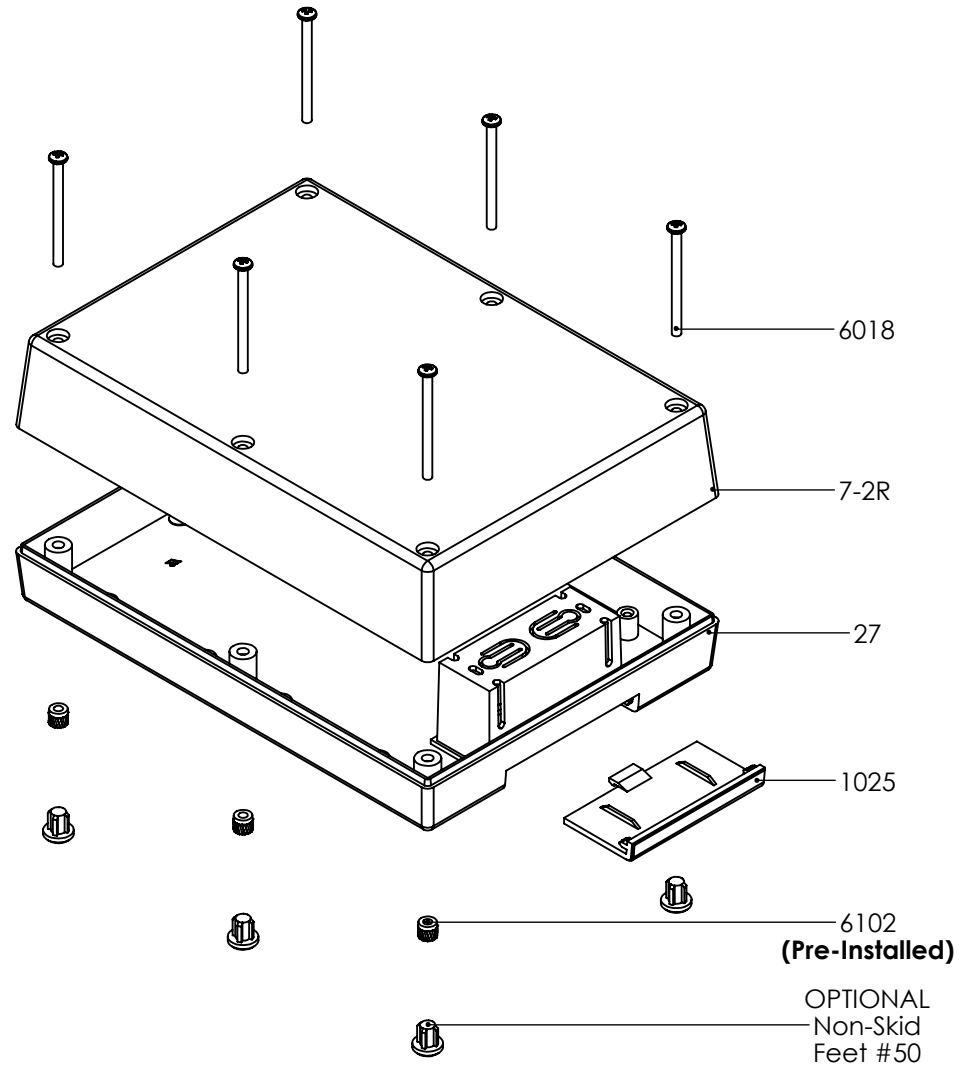
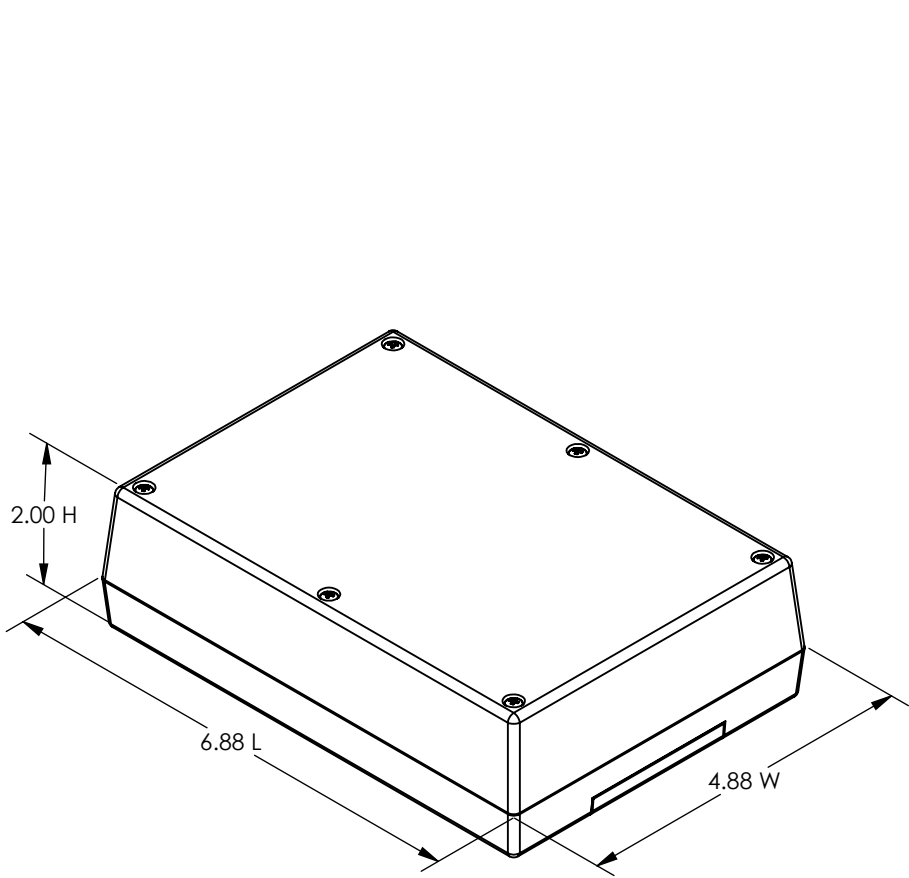

PART NO.	DESCRIPTION (Included)	ACCESSORIES (Optional)	
7-2R	Top	PART NO.	DESCRIPTION
27	9V Bottom	1040	2AA Battery Holder
1025	Battery Cover	50	Non-skid Feet
6018	4-40 x 1 1/2" Screw (6)	60	Standoff Hole
6102	4-40 Threaded Inserts (6)	61	Standoff Post

Notes: Enclosure weight .46 lb / 210 g  
 1) Enclosure meets or exceeds IP40 and NEMA 1  
 2) Circuit Board drawings see sheet 3.  
 3) All components are RoHS Compliant.  
 4) Material: Top and Bottom ABS.

# SERPAC 272R

ELECTRONIC ENCLOSURES

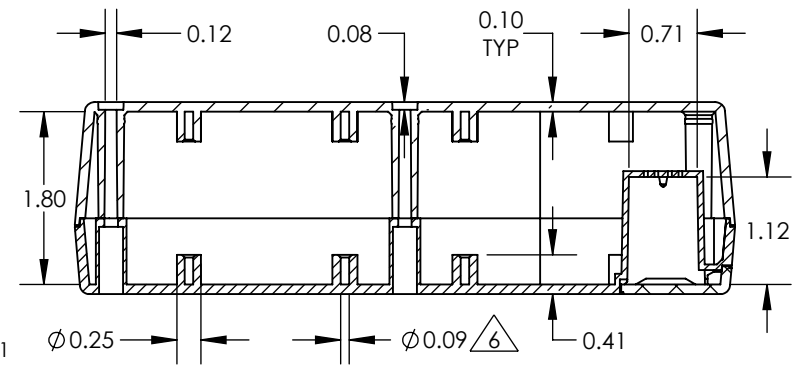
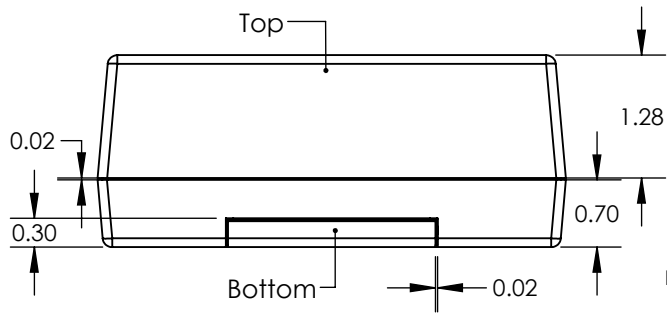
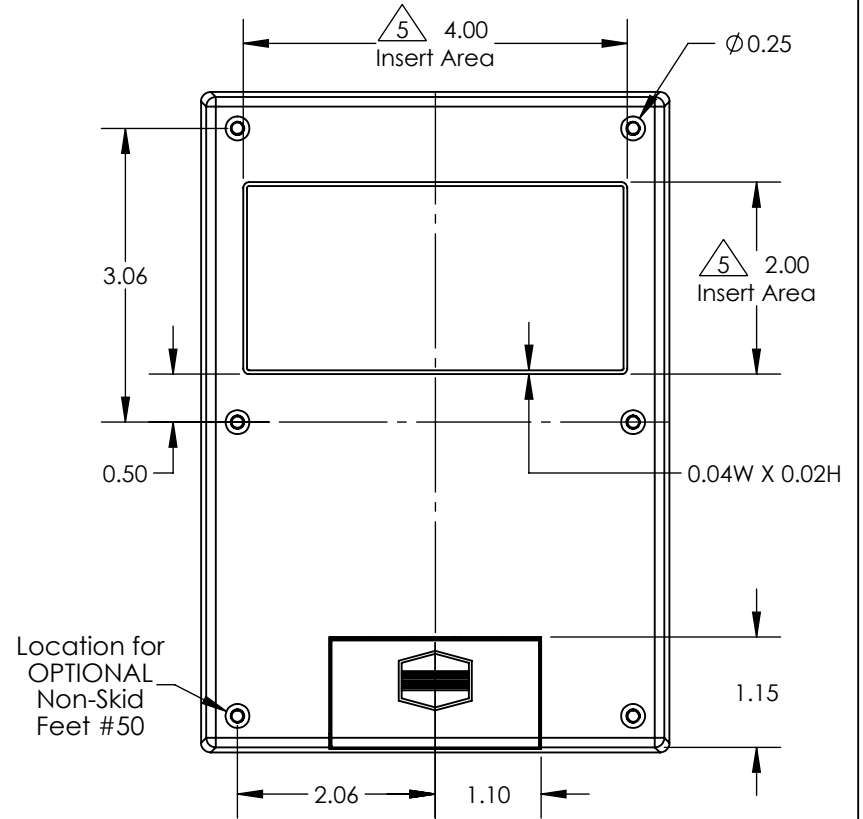
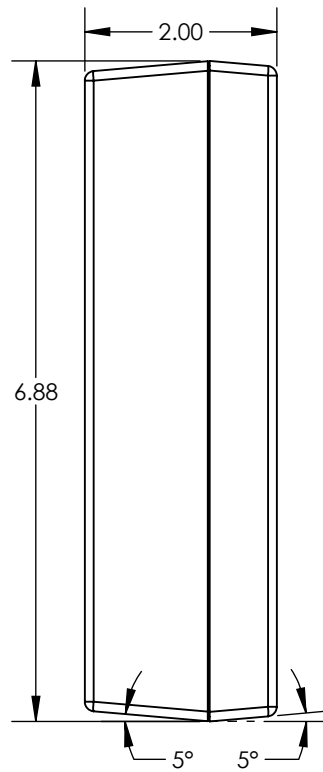
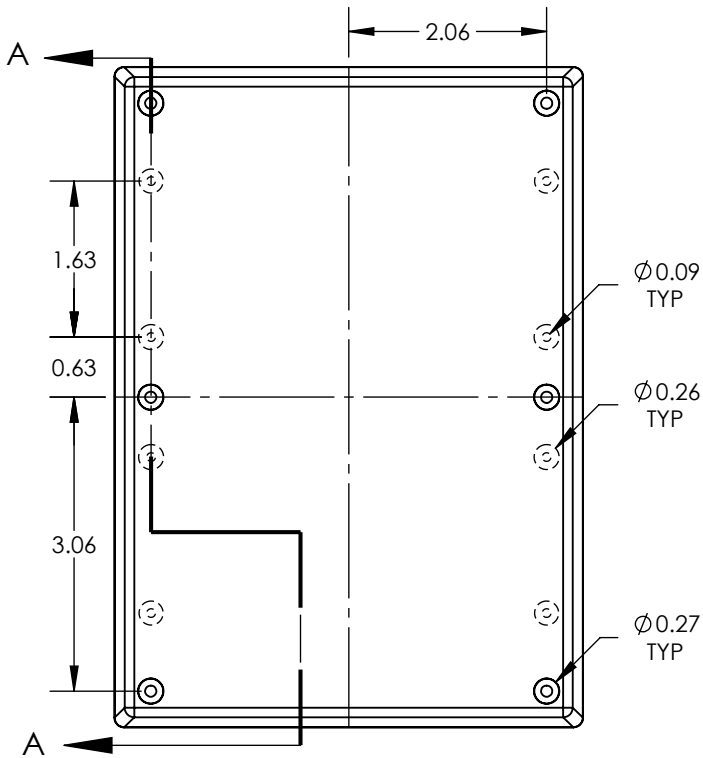

- Notes:
- 1) Enclosure weight .46 lb / 210 g
  - 2) Enclosure meets or exceeds IP40 and NEMA 1
  - 3) Circuit Board drawings see sheet 3.
  - 4) All components are RoHS Compliant.
  - 5) Material: Top and Bottom ABS.
  - 6) PCB Bosses accept #4 self tapping screw.

# SERPAC 272R CIRCUIT BOARD

ELECTRONIC ENCLOSURES

## Top Option

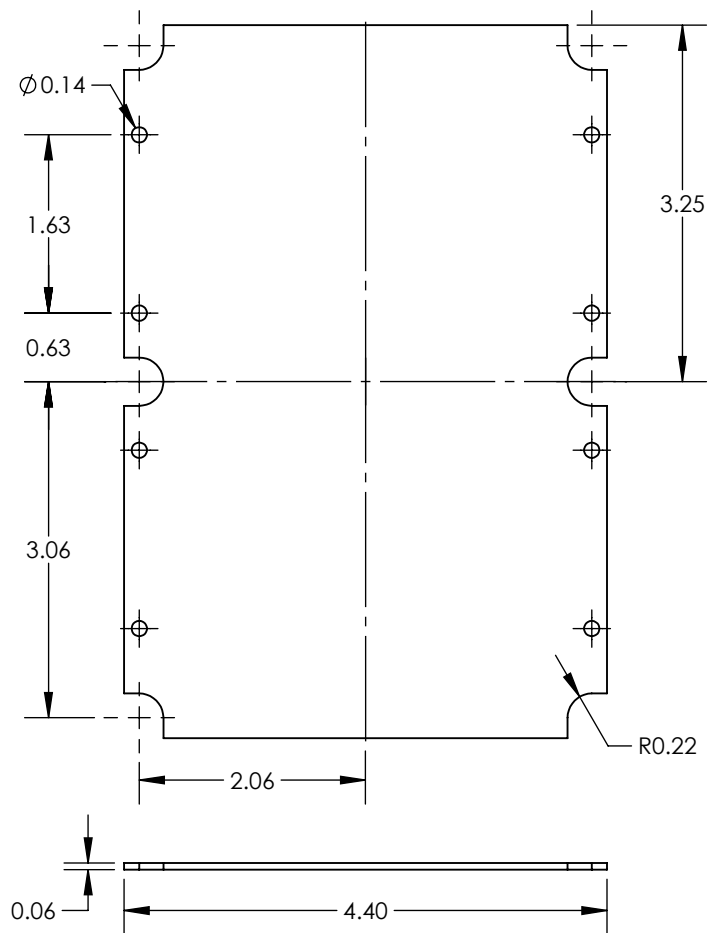

## Bottom Option

