

SERPAC 153W

ELECTRONIC ENCLOSURES

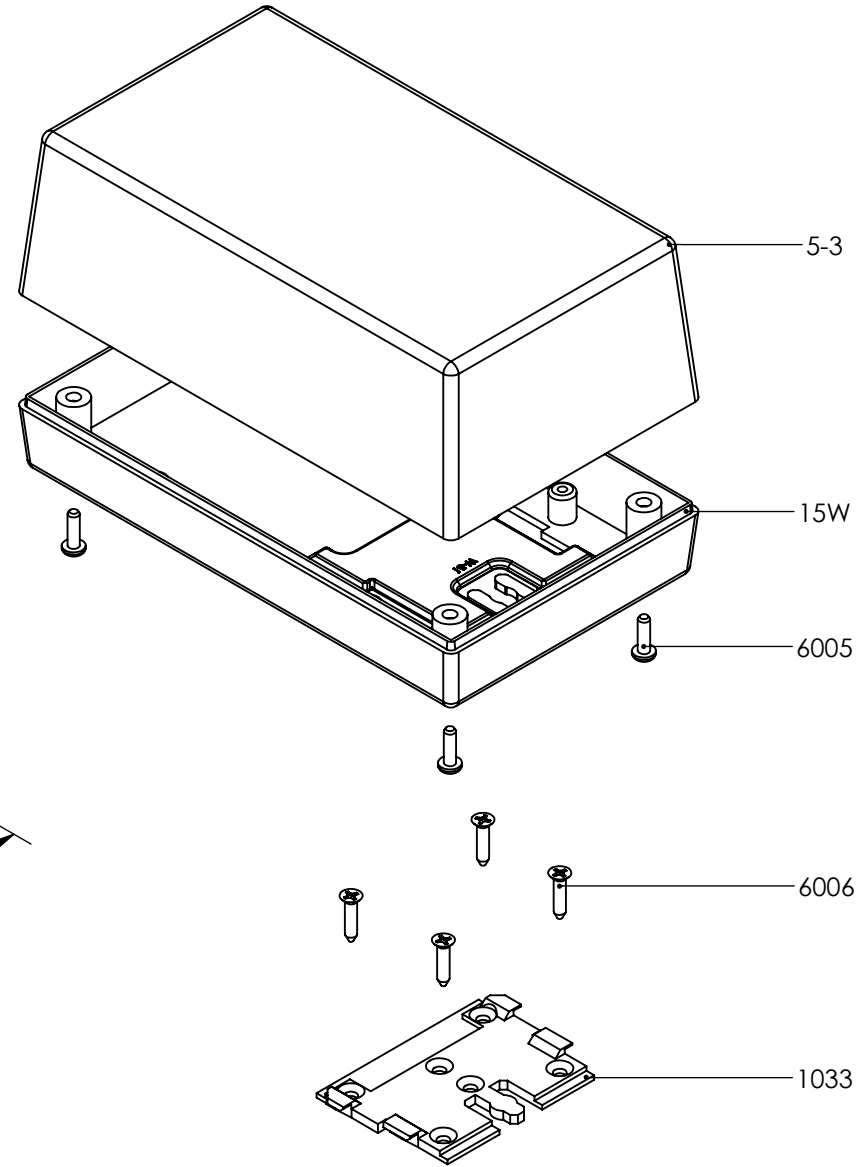
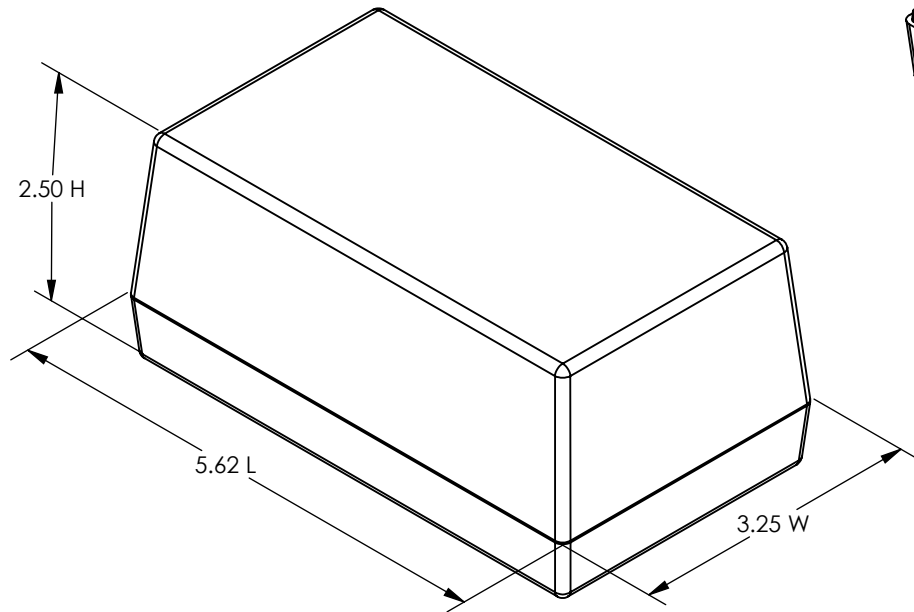

PART NO.	DESCRIPTION (Included)	ACCESSORIES (Optional)	
5-3	Top	PART NO.	DESCRIPTION
15W	Bottom	1040	2AA Battery Holder
1033	Wall-Mount Plate	60	Standoff Hole
6005	#4X3/8" Self-Tapping Screw (4)	61	Standoff Post
6006	#4X1/2" Self-Tapping Screw (4)		

Notes: Enclosure weight .30 lb / 138 g
 1) Enclosure meets or exceeds IP40 and NEMA 1
 2) Circuit Board drawings see sheet 3.
 3) All components are RoHS Compliant.
 4) Material: Top and Bottom ABS.

SERPAC 153W

ELECTRONIC ENCLOSURES

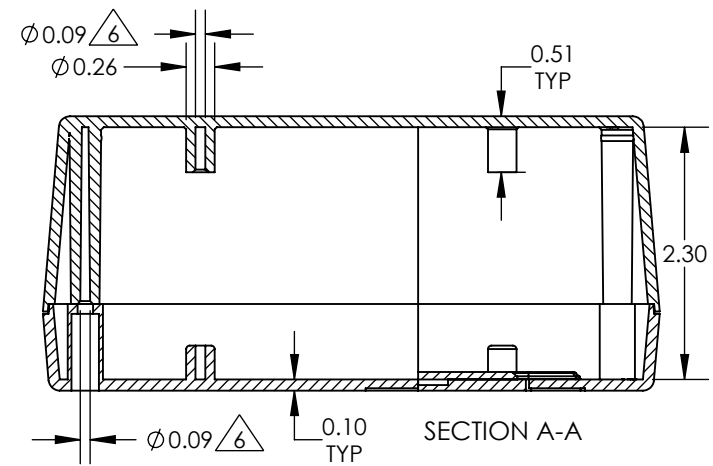
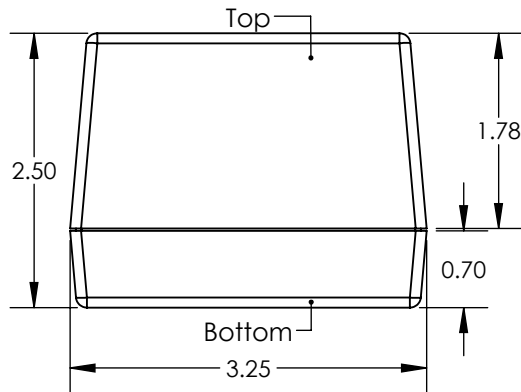
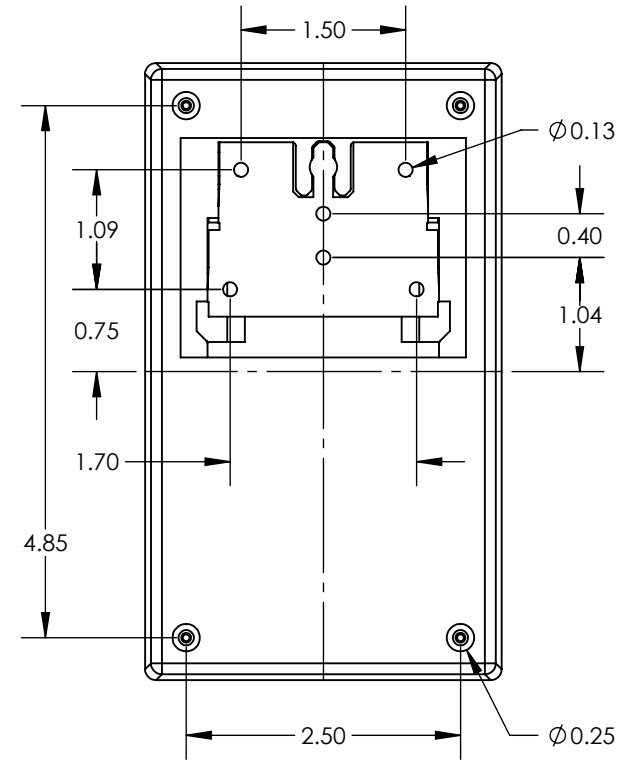
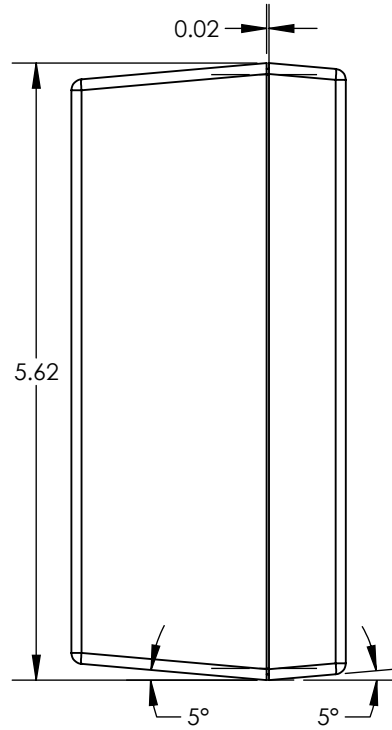
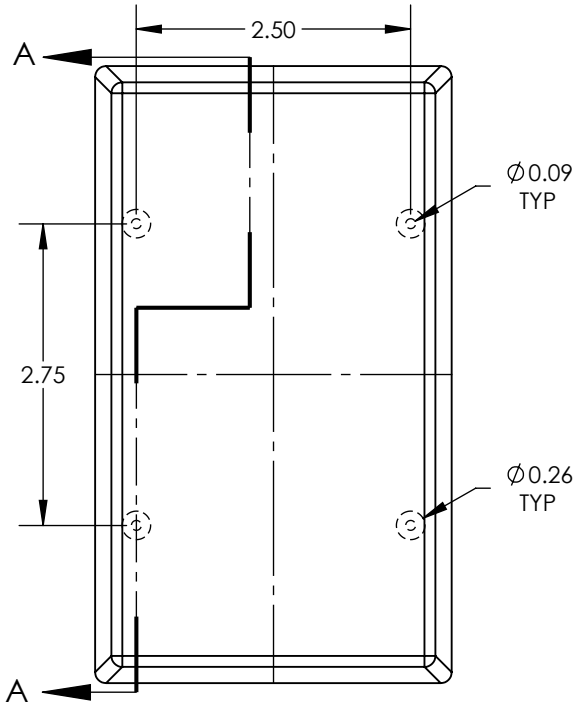

- Notes:
- Enclosure weight .30 lb / 138 g
 - 1) Enclosure meets or exceeds IP40 and NEMA 1
 - 2) Circuit Board drawings see sheet 3.
 - 3) All components are RoHS Compliant.
 - 4) Material: Top and Bottom ABS.
 - 5) Customizable molding areas. $\triangle 5$
 - 6) PCB Bosses accept #4 self tapping screw. $\triangle 6$

SERPAC 153W CIRCUIT BOARD

ELECTRONIC ENCLOSURES

Top & Bottom Option

